

Wall Painting And Stucco In Jordan: From Miniature To Megalography

Introduction

Every year new painted or stuccoed decorations appear in Jordan, dating from the Nabataean and Hellenistic periods to the Umayyad Caliphate¹. For example, Petra regularly brings up new Nabataean examples and at Gerasa a recent late Hellenistic discovery on the lower terrace of the Zeus temple represents an important development in the history of ancient wall-painting. In addition, conservation interventions have brought new iconographic indications and readings to light, as at Quşayr 'Amra whose Umayyad paintings are inscribed on the UNESCO World Heritage list. Known since Musil's publication (1907), from 2011 onwards new pictures and inscriptions hidden under excessive conservation measures dating back to the mid-1970s have been spectacularly revealed². The bibliography is also increasing, thanks to archaeological reports, articles, theses on so on³: *e.g. Peintures et mosaïques mythologiques en Jordanie* (Zayadine 1986:

407-432); *From the Decapolis to the Umayyad Palaces* (Tell 1995: 375-382); *Quşayr 'Amra* (Vibert-Guigue and Bisheh 2007: 3-23).

The 2013 ICHAJ colloquium in Berlin was an opportunity to remind ourselves of the archaeological importance of stucco and painted art in ancient Jordan. Three main points can be made. First, the transition from 'art stucco' (mortar decoration with finishing relief) and 'art painting' (smooth surface, without relief)⁴. Initially, under Greek influence, the plastering or coating imitated monumental ashlar masonry in stucco, within the context of interior decoration. Stucco block work modelled in relief with drafted marginal masonry and well-fitting joints were considered essential. Second, figurative subjects can be discussed as a significant evolution over time and in different contexts. Human or animal representations seem to appear at the end of the Hellenistic period and subsequently increased in size. This can be illustrated by comparison of

1. This survey is based on fieldwork started in the late 1970s at the French Institute of Archaeology in 'Ammān at the request of the Department of Antiquities (Abila, 'Ammān, Bayḏā', Jarash, Petra, Quşayr 'Amra *etc.*), focusing here on archaeological rather than historical evidence.
2. Quşayr 'Amra is the subject of a new conservation program run by the DoA in partnership with the *World Monuments Fund*[®] and the *Istituto Superiore per la Conservazione ed il Restauro* in Rome. The Jordanian - French documentation survey (DoA – IFAPO [1989 – 1997]) was the first to highlight problems with the 1970s restoration, which included modern repainting.

3. Many others could be listed: Petra (MacKenzie 1991); Qaşṭal (Bisheh 2000); Qaşr al-Ḥallābāt (Arce 2009); Deir 'Ain 'Abata (Politis 2012) *etc.* Complementary bibliographical references are in the text and a selective bibliography is included; a map shows sites (a single point could indicate one site or many, as at Petra, Jarash, Abila *etc.*).
4. There is a problem of vocabulary in the various modern languages. Most of the time, only analyses can differentiate mortar (sand; water; lime) from plaster (gypsum), or *fresco* from *tempera* (painting on wet or dry mortar). As techniques could be combined, this issue must be studied carefully with appropriate methods.

two examples at opposite ends of the temporal spectrum, *viz.* the late Hellenistic painted *biclinium* at Bayḍā' (*ca.* 15 cm-high figures) and the Umayyad bathhouse at Quṣayr 'Amra (life-size figures). In short, figures go from miniature to megalography. Third, Jordan offers many opportunities to analyze *in situ* mural decoration. The surface base for painters could be built or cut into rock, outside, underground or mid-cliff.

Paintings in monuments are common, but although painted tombs offer a vast field of research, ancient housing is under-represented. This might be explained by the fragility of the mortar, which was unable to survive successive reoccupations of a city. Plaster is also less strong than flooring. As a result, antique wall paintings in association with mosaic floors are unusual. The discoveries have instead involved Byzantine churches or palaces, with

interesting pavements still displaying Roman mythological and cultural influences (Zayadine 1986). Byzantine mosaics with human or animal figures were subsequently an important area of transition for artisans working on the later Umayyad residences.

The number of sites amounts to approximately 30, ranging in date from the Hellenistic period to Umayyad times (FIG. 1). From north to south there are three main zones: north Jordan with the Decapolis, a central zone around Amman and a third extending from the southern end of the Dead Sea to the Red Sea. A fourth zone in the east covers the Umayyad residences in the *bādiya*. As space precludes a systematic presentation, this article will focus instead on a quick chronological overview of some well-known remains, as well as others that have not been well-documented or have been forgotten. These constraints mean that apologies are

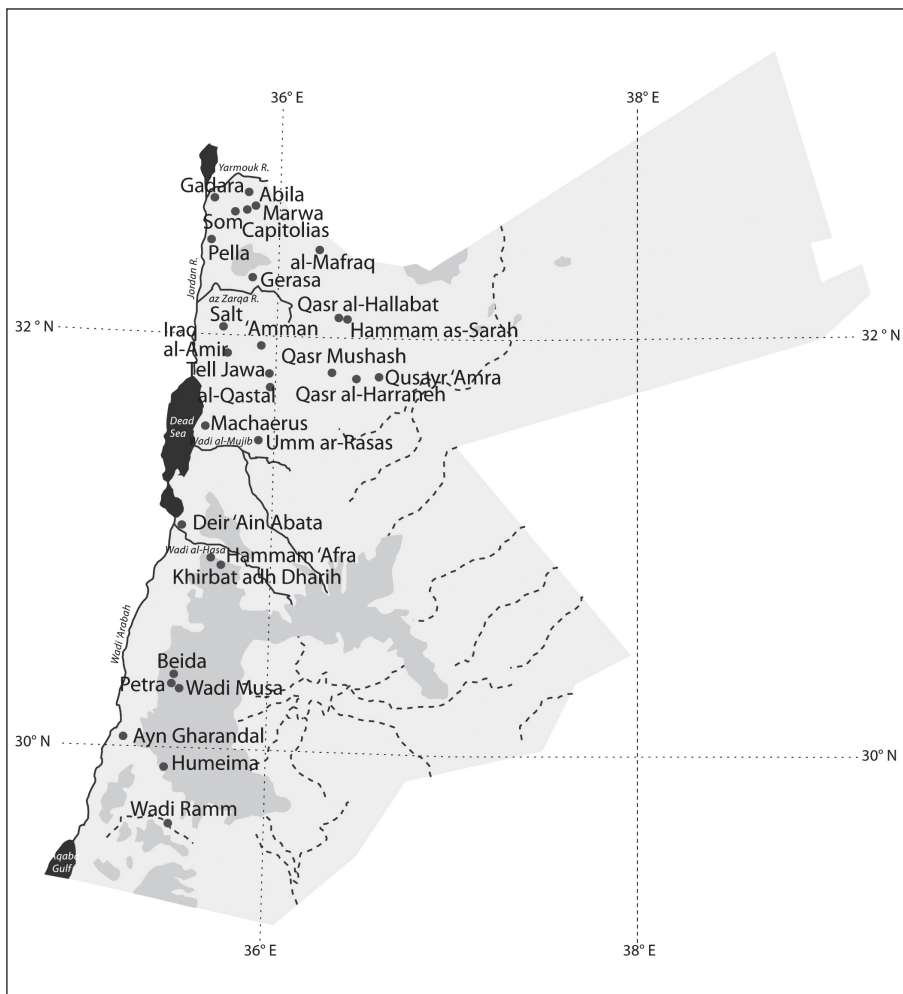

1. Sites with paintings or stuccos in Jordan (Vibert-Guigue).

offered to scholars whose discoveries have not been included⁵.

Before presenting a preliminary inventory, two examples deserve special mention because they approach the issue of wall-covering in different ways. Qaşr al-‘Abd at ‘Irāq al-Amīr (Wādī as-Sīr) is one of the few mid-period Hellenistic monuments preserved in the Near East. It is well known for its megalithic building techniques and larger than life-size sculpted animals (lions; eagles; panthers). Dating back to 175 BC and notwithstanding the fact that it is uncompleted, the monument preserves some fragments of Hellenistic painted stucco within the south vestibule (FIG. 2). A few pieces represent an ornamental moulding, imitating a masonry frame. It may be one of the earliest examples of imitation masonry (‘structural, or incrustation style’ according to some scholars) inspired by the Greek *koinè* that extended from Macedonia to Asia. In 1991, Will wrote that the stucco plasterers’ team began to coat the first level of the castle around the windows and Corinthian capitals (Will 1991: n. 33, 309)⁶.

The second example is from a rock-cut context at Nabataean Petra. A recent study has reiterated that carved facades were painted

(Aslan and Shaer 1996; Shaer 2003), a fact known for many years (Zayadine 1987: 131). Using computer reconstruction (FIG. 3), evidence from many small patches of colour on facade tomb 826, which has a *terminus ante quem* of 50 AD (McKenzie 1990: 110), has been considered. Do these decorations belong to the first occupation of the tombs, and how did the colours or plaster stop around each carved facade? Some of these facade tombs are very close to each other, so we wonder how this polychromatic ‘vicinity’ was understood.

In both these examples, there is a strong link between the architecture and the coating, regardless of whether the structure is of classical or oriental inspiration (or mixed), or built or rock-cut. We have also to remember that the action of coating is typically the final phase of any architectural project, aimed at finishing the surfaces and protecting the structure. It should also be borne in mind that a single construction could see changes of mural decoration through time, or that the original decoration might survive even if the function of the construction changed. Paintings that remained *in situ* force us to consider later people from other cultures or religions who may still have accepted them.

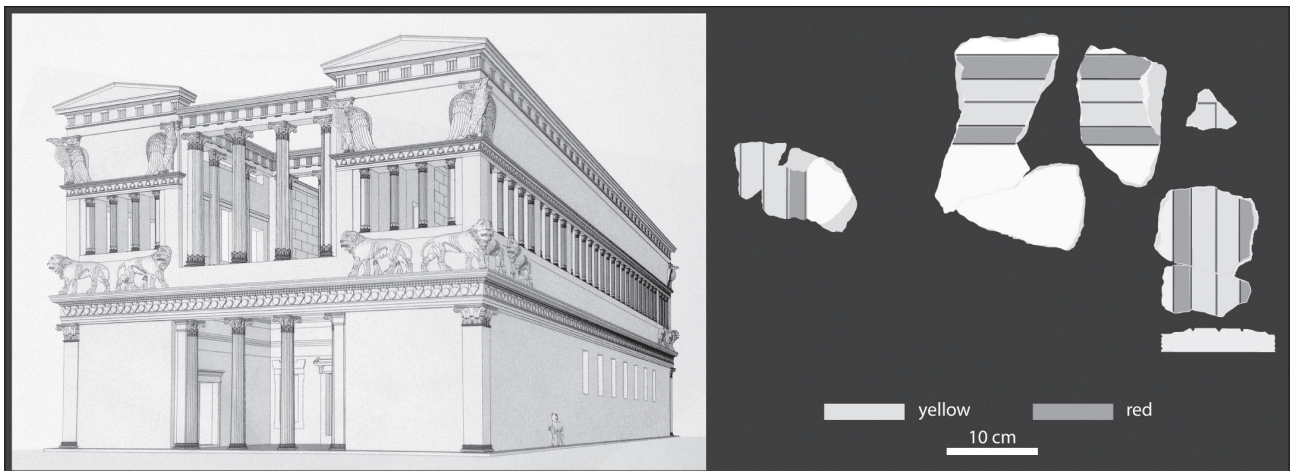

2. ‘Irāq al-Amīr: (left) reconstruction (Larché 2005: ill. 24); (right) fragmentary painted stucco (Will 1991: fig. 40; Vibert-Guigue).

5. Pella (Smith 1981), Gadara (Kerner 2002), Tall Jawa (Daviau 2010), Machareus (Vörös 2013) *etc.*

6. The building was reoccupied during the late Roman period and during Byzantine times it was decorated with painted plaster. The ‘Iraq al-Amīr Hellenistic area makes it possible to study a

‘plaster house’ in the village in front of the cliffs, a few kilometers north-east of the castle (Lapp 1963; Groot 1980). Column drums display stucco decoration in imitation of fluted columns (unpublished).



3. Petra - polychrome study of a tomb façade: (left) “Mapping of plaster and paint remains on the facade of Tomb 826”; (right) “Hypothetical reconstruction of the facade of Tomb 826” (Shaer 2003: figs 25 and 28).

In view of these issues and dating problems at many sites, particularly in rock-cut contexts, this paper takes a broad chronological approach without strict limits.

Stucco-Painting Evolution at Petra and Bayḍā’: From ‘Masonry Style’ to other Stuccoed Features and From Non-Figurative to Figurative Stuccos or Wall Paintings

Jordan gives us the possibility of analysing the Greek imprint at the Nabataean city of Petra, under Hellenistic - Alexandrian influence, followed by late Republican Roman impact. This period, which sees a shift from non-figurative masonry to figurative styles, can be analyzed from the theoretical perspective of chronology and ornamental evolution in six categories, the last concerning stuccos and wall paintings in built temples at Petra. Different factors must be considered, such as location, technique, religion, integration of figures and external contexts (whether at Petra or Bayḍā’). Specific Nabataean characteristics, such as rock-cut caves or built monuments, will be highlighted.

Masonry Stucco in Caves at Petra

After ‘Irāq al-Amīr, the most ancient mural

stucco decoration known in Jordan is at Petra. Located in the middle of the eastern cliff of al-Ḥabīs, the large stucco remains of two back walls belonging to two adjacent rooms are now out of context. An earthquake destroyed this part of the cliff, in which a now inaccessible luxurious dwelling cave was once situated (Zayadine 1987: 135-136). For this reason the exact dimensions of the walls are unknown. The hypothesis is that the smaller room (left) could be ‘around 3.70’ metres high and the larger (right) ‘around 6.12’ metres. Both examples have stucco masonry. On the left wall, from the bottom up, a narrow plinth, orthostats, a string course and stone courses (*opus isodumum*) alternate with horizontal cornices, smooth courses and vertical niches or windows with moulded frames. The decoration of the right-hand room (FIG. 4) consists of elaborate stucco in the left corner. A large cornice supports a double fluted column. In the upper part of the wall there is a second level of architecture, with engaged pilasters imitating a gallery. This type of decoration is well-known around the Mediterranean; the upper gallery of Qaṣr al-‘Abd at ‘Irāq al-Amīr (FIG. 2) is an interesting parallel (Zayadine 1987: 134). The al-Ḥabīs ‘masonry style’



4. Petra - al-Ḥabīs caves: *in situ* stucco decoration (Vibert-Guigue).

could date to at least the beginning of the 1st century BC.

Masonry Stucco in Built Contexts at Petra (Zayadine 1987: 137)

Not far from al-Ḥabīs, built monuments possibly dating to around the mid-1st century BC preserve stucco imitating architecture. Near the Temenos gate, the so-called ‘bathhouse’ shows the difficulty of studying material excavated in 1968 (Zayadine 1987: 139). In the 1980s, at the request of the Department of Antiquities (DoA), I drew large stucco block fragments collapsed from a built cupola that once covered a circular room. More recent drawings elaborated by computer give a rough idea of the room, which was stone-built with engaged columns and niches between them (FIG. 5). One section of the fragmented stucco belongs to an entablature (architrave; frieze; dentil cornice) with a final *simā*. Coloured motifs (egg-and-tongue; egg; Lesbian kymation; scrolls) are painted on the white stucco relief. Above, further decoration is more hypothetical. It started with stucco ribs, reaching an *oculus* still open at the top of the cupola. It seems that the stucco does not imitate a ‘coffer cupola’, as at the Pantheon in Rome. It could instead be an ‘umbrella’ type, using ribs

represented by a red groove on the main face⁷.

Immediately adjacent, a monumental staircase has been excavated, with stucco decoration still present on the walls despite the collapse of the roof (FIG. 6). A computer reconstruction gives an idea of the architectural stucco decoration, with red and yellow orthostats and *opus isodomum*. These two motifs with relief are well-known at Petra and Bayḍā’. This sector is believed by scholars to be a palatial complex, with a vestibule entrance close to the Temenos gate.

Stucco and Figurative Wall Paintings in Rock Contexts at Bayḍā’

The combined use of stucco and paint characterises remains found in 1898 at Bayḍā’, located north of Petra in Sīq al-Bārid. Here the decoration is quite different, as it includes many figures (Zayadine 1986: 408-411) (FIG. 7). It is a *biclinium*, hypothetically interpreted as an Isiac complex (Twaissi 2010). In 1980 the DoA asked me to undertake a complete drawn and photographic survey, which yielded interesting results. Recently, careful cleaning has been carried out by the Courtauld Institute of Art and Petra National Trust (Akrawi and Shekede 2010), which has returned the paintings to their original light delicate colours. Strangely,

7. It is worth noting that two cupolas of the Umayyad period do not display coffer designs. At Ḥammām aṣ-Ṣarāḥ there is a geomet-

ric umbrella pattern, while at Quṣayr ‘Amra geometric painted lines can be interpreted as a celestial cupola.



5. Petra - so called 'bathhouse' near the *temenos* gate: stucco cupola (fragmentary discovery) (Vibert-Guigue).

only the back wall of the *klinè* room is plastered. It is covered by an *opus isodomum* above two orthostats. An alcove opens in the middle, decorated by a stucco frame imitating a pergola with pilasters, cornices and arches. The painted surfaces between the stucco represent beautiful grapes, plants scrolls, flowers, birds and Erotes. Banqueters lying on the *klinè* would have been able to observe it as a splendid natural symbol of abundance, probably honouring Dionysus. Rainwater was channelled from the cliff to fill basins and a reservoir for rituals. A small *betyl* is carved in the rock at right of the entrance. In this natural, quite wild scene, the fine representation of a pergola at the bottom of the carved *biclinium* was a 'scenic masterpiece', reminiscent of the famous Roman mosaic of Preneste that is frequently quoted in the literature.

Right in front of the narrow gorge and cut

into the opposite cliff is a cave with a low bench running along the walls. The walls are decorated with an *opus isodomum* and the ceiling with a painted coffer without stucco, except for a central medallion. The ashlar masonry displays incised joins to imitate real ones, while the tops of the walls have only a series of holes to attach a lost decoration. Unfortunately this exceptional decoration, seemingly without figures, has been obscured by smoke.

Wall Paintings and Stucco in Built Contexts at Petra

In the 1990s, a Swiss - Liechtenstein team excavated a painted house at az-Zantūr IV (Kolb 2002) where one room was particularly rich. On the main part of one wall, painters carefully represented a kind of *aedicula* with an imitation of a painted *opus sectile* in the panels.

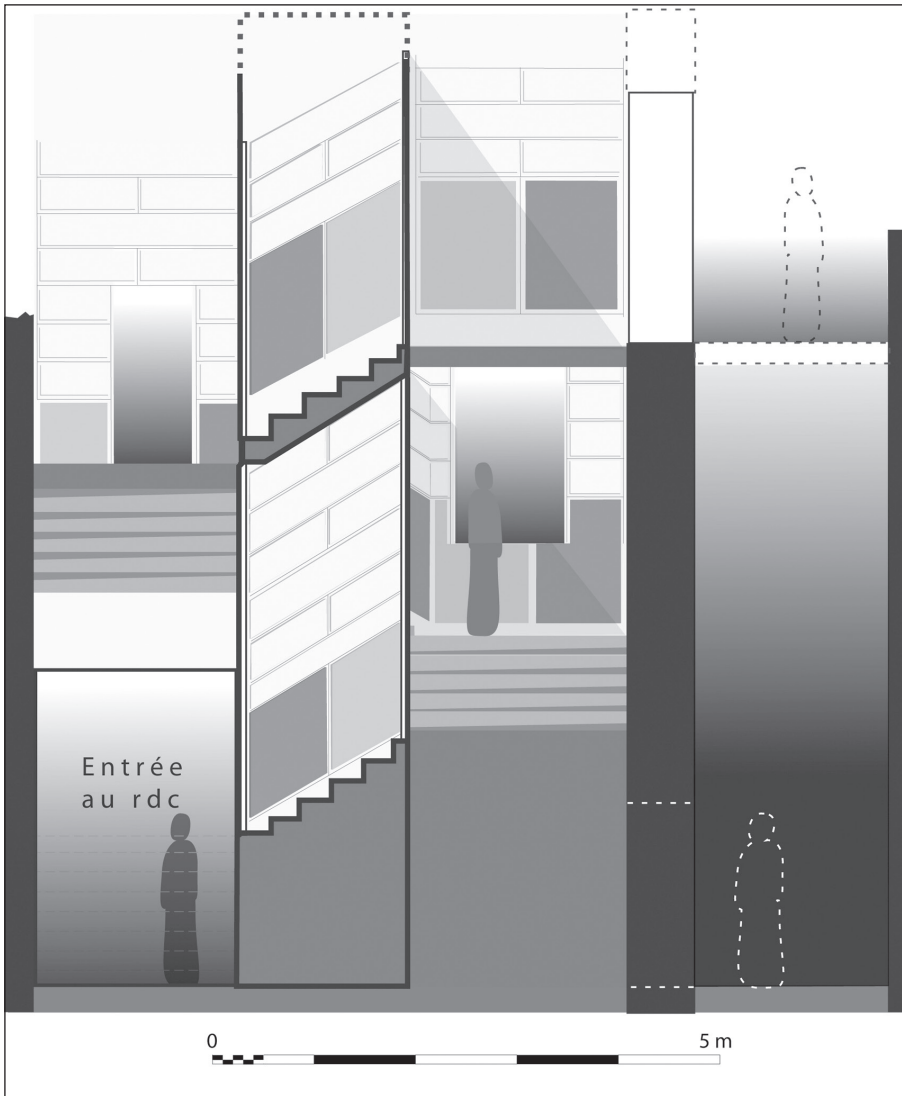

6. Petra - staircase near the *temenos* gate: *in situ* painted stucco (Vibert-Guigue).

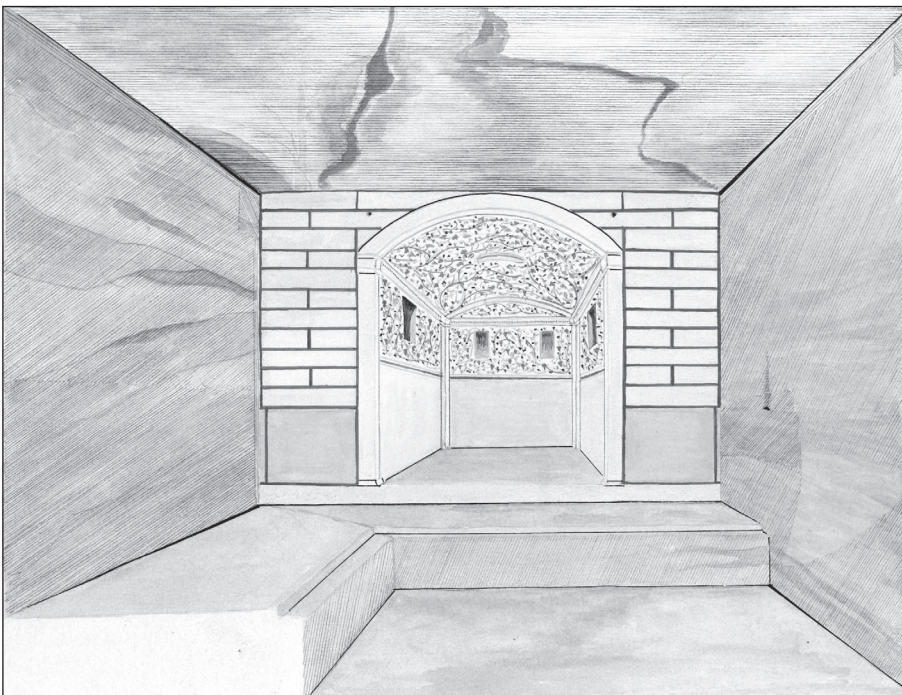

7. Baydā' - Sīq al-Bārid *bi-clinium*: *in situ* painting and stucco (watercolour Vibert-Guigue).

Two small medallions with Gorgon heads rest on the top of the *aedicula*. The upper register of the wall was covered by stucco decoration, as was the *tympanum* surface corresponding to the barrel vault. This international project aimed to protect a reconstruction of the decorated room *in situ*, covered by modern protection. ‘Masonry style’ appears also in this house.

Wall Paintings in Rock Contexts at Petra and at a Villa in Wādī Mūsā

Wādī Siyagh at Petra preserves caves cut into the cliff faces, probably for use as dwellings. A small, completely painted example was discovered in 1979 by N. Qadi and I (Zayadine 1987: 140) (FIG. 8). Polychromatic facades are aligned in the lower zone, while the upper zone displays a geometric pattern inspired by cubes in perspective. A large circular composition is painted on the ceiling, but unfortunately the colours have vanished (Vibert-Guigue 2010). The only figurative element is a ‘schematic bird’ in the lower part, on the short wall to the right of the door.

In 2000, in the built-up area of Wādī Mūsā (FIG. 9), a rich villa was excavated by the DoA at Jabal az-Zuhur. A wall painting was found, which has been removed for exhibition

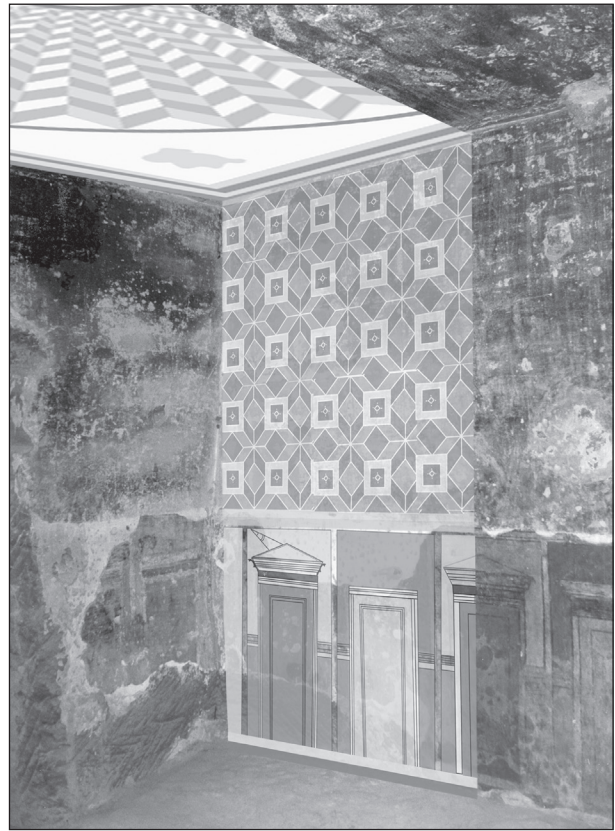

8. Petra - Wādī aš-Şiyagh: fully painted cave. The picture is partially enhanced by computer (Vibert-Guigue).

in the Petra museum; it has been described thus: “Although similar to other frescos from Wādī Mūsā and Petra, it is unique in having representations of birds (a heron, a sparrow

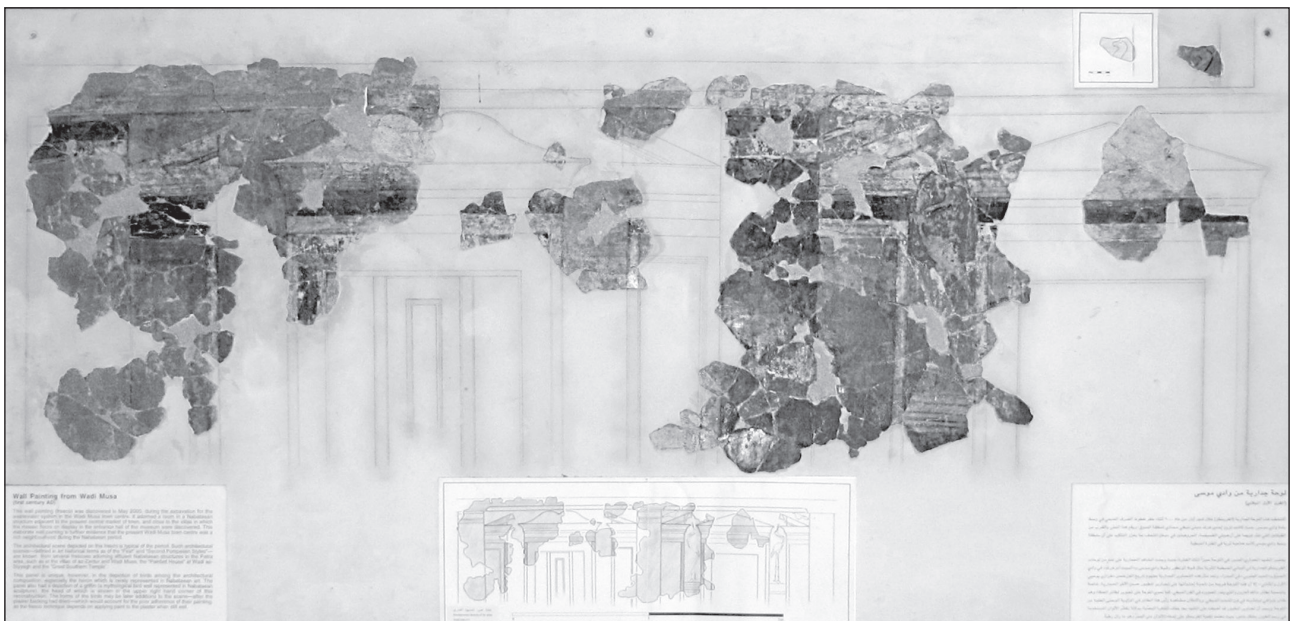

9. Wādī Mūsā - villa: Fragmentary paintings (‘Amr 2001).

and a phoenix) among the architectural scene” (‘Amr and al-Momani 2001: 266). A mosaic found nearby suggests a Nabataean context for the villa of around the mid-1st century AD.

Stuccos and Wall Paintings in Built Temple Contexts in Petra

The high walls of Qaṣr al-Bint are perfect for monumental stucco decoration. The vestibule and *naos* display figurative subjects (human and mythological) using the stucco technique of fixation (Zayadine 2003). Indeed, this stuccoed *opus isodomum* is exceptional in terms of its size. Each block, framed by a cornice, is about 1 m high by 4 m long, being four times greater than the average observed at Petra and Bayḍā’. Within each frame, Larché recorded a numerous holes used to attach stucco (human and animal figures; vegetation). Stucco *Niké* figures were also present. The date appears to be around the start of the common era.

In the Temple of the Winged Lions, painted Eroses amongst vine scrolls in niches and a painted frieze with figures and stucco heads have been found (Hammond 1996). Conservation measures are ongoing (Tuttle 2013) and a publication project will describe the paintings and stucco.

The case of the Petra Great Temple is quite different (Joukowsky 2007): the non-temple function of the building has been discussed (Kropp 2009: 43, n. 3). Only one human face has been found on a painted fragment (Joukowski 2007: fig.7.9), in addition to two moulded stucco lion protomes (Egan 2002: 359-360).

The main vestiges of the decoration consist of painted plaster with *in situ* stuccoed architectural elements in the upper *temenos* corridor. It shows mainly architectural and schematic patterns, with a difference between two sections. The west corridor has painted frontal facades between stucco pilasters segmented by cassettes. In the south corridor, preliminary studies describe ashlar compositions (orthostats, *opus etc.*) between

stuccoed pilasters segmented by cassettes. The main difference appears in the form of fragments imitating the marble making up the *opus*. The decoration of the central doorway is more elaborate. Pieces of stucco and paintings indicate a round, segmented pediment, with the possible presence of two moulded lion protomes on either side of the architrave (Egan 2002: 359). A publication being prepared by the American team will shed light on the corridor decoration, which seems to have been modified in line with the phases of the building.

To sum up this overview of decoration in the Nabataean mountains, it seems that after a period of stucco art, during which a Greek architectural masonry style developed, human figures appeared - in temples, as at Petra, or in semi-religious contexts, as at the Bayḍā’ *biclinium*. The latter was associated with a kind of sanctuary, or at least with a ‘ritual meeting / banqueting’ location (perhaps for a *thiase*), far from the Nabataean city centre.

Evolution of Painting and Stucco in North Jordan

The Decapolis cities of northern Jordan stand in contrast on account of their very different geographical settings. The mural decorations date from the mid-1st century BC to the 3rd century AD. Here, once again, we can observe a slow process during which architectural stucco became less dominant, being replaced by painted plaster.

A late Hellenistic ‘*naos*’ from the lower terrace of the Temple of Zeus at Jarash displays decoration featuring stucco and painted plaster without figurative representation (Eristov and Seigne 2003). Carefully dismantled at around the time of the first Jewish revolt (66 - 73 AD), by chance the decoration was still attached to the blocks when they were re-used in the foundation of a second sanctuary (FIG. 10). Fluted stucco pilasters divide each interior wall: in the gaps between them, in the lower zone (one excavated wall fragment has survived *in situ*), we find a

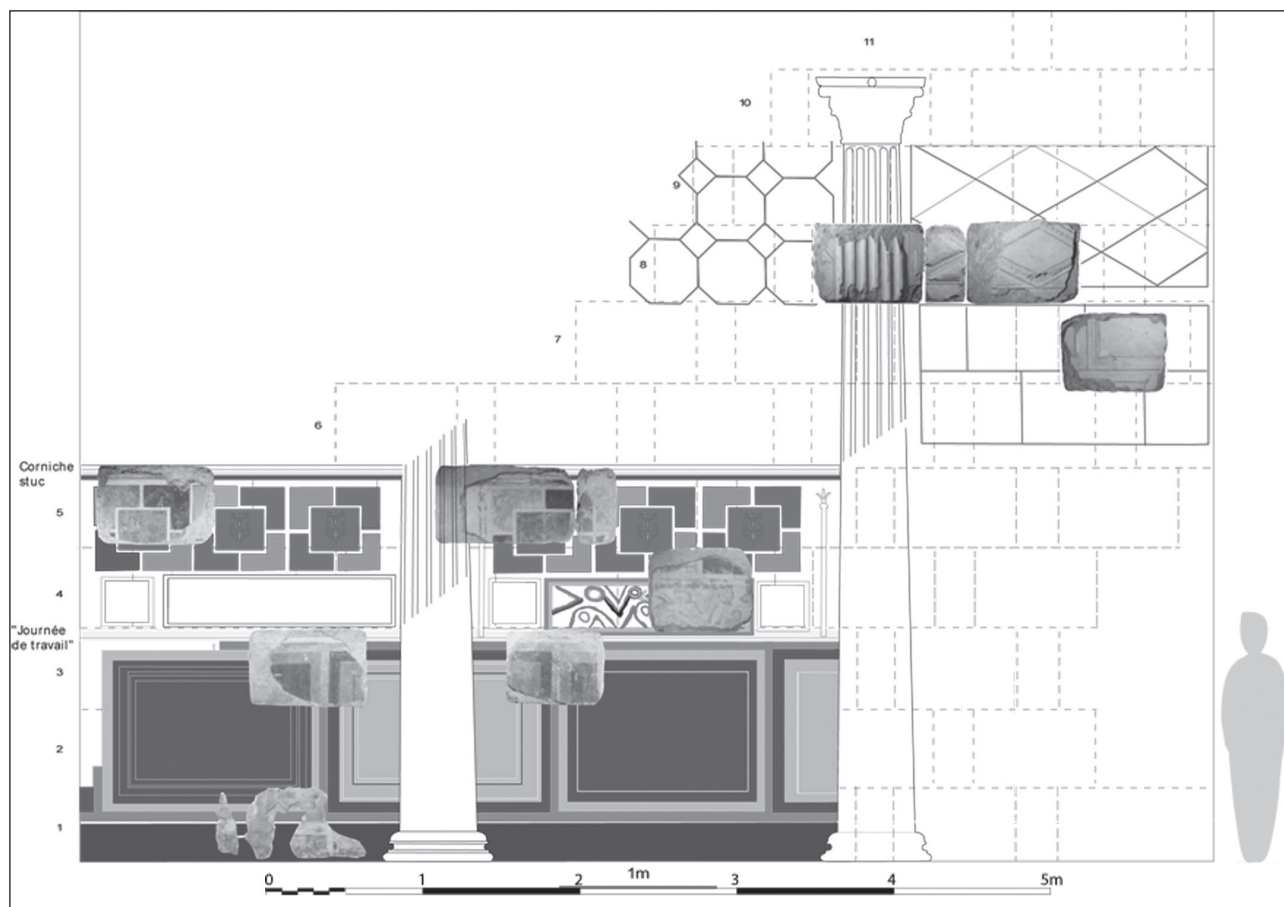

10. Jarash - Zeus sanctuary: *in situ* painting (dado) and dismantled blocks preserving stucco and painting (Eristov and Seigne 2002; Vibert-Guigue).

narrow plinth, orthostats and a course of blocks imitating coloured marble. Above them, there are panels organized in a gamma composition topped by vegetal motifs. These two registers (low and mid-level [painted plaster only]) are interrupted by a stucco cornice. The upper zone is different. Stucco relief ashlar are present in *isodomimic* courses, along with at least two grid-pattern motifs consisting of octagons or lozenges underlined by a line of eggs and red lines (Eristov and Seigne 2002).

The necropoleis of the Decapolis are well-known for their painted tombs, mainly from the 2nd and 3rd centuries AD. More than thirty tombs are known, with many painted figures and inscriptions (FIG. 11). The Abila necropolis is one of the most important; painted tomb no 3 gives an idea of the interior organization

(Barbet and Vibert-Guigue 1988). The bodies were in two rows of horizontal graves (*loculi*) cut into the wall⁸, thereby reducing the area of wall surface to be decorated. The painters found a solution by imitating columns in the vertical intervals and representing small figurative scenes or animals in the horizontal registers. The alcove in front of the entrance had different decoration, emphasising painted 'portraits' of the deceased, funerary inscriptions and elaborate geometric patterns on the narrow vault. Only the ceiling of the main room allowed a large composition, consisting of a geometric / vegetal pattern including masks and objects. An eagle is painted within the central medallion.

Even smaller, the *arcosolia* tombs offered tympanal surfaces (FIG. 12). At Beit Ras (*Capitolias*), two Trojan episodes are depicted

8. Masonry closed the *loculi* after the placement of the body. Each was painted (vegetal crown, inscription *etc.*) independently of the painted wall of the tomb.

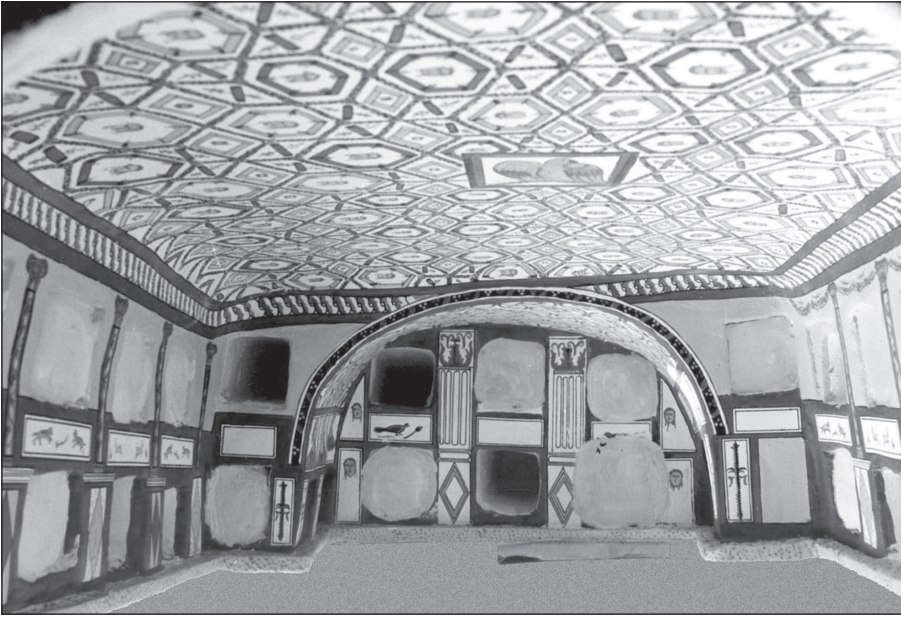

11. Abila - Roman *loculi* in tomb Q3: *in situ* funerary paintings (Vibert-Guigue).



12. Bayt Rās (Capitolias) - Roman *arcosolia* tomb: funerary paintings *in situ* (Vibert-Guigue).

(Zayadine 1986:); the fight between Hector and Achilles, who drives his spear into Hector's body, and Achilles attaching Hector's body to a chariot to drag it in front of the walls of Troy.

Inside the tombs, the technique of stucco is almost absent, being used only to decorate the closure of the *loculi*. In one interesting case, a wide stucco shell is preserved in a tomb at Gadara (Karasneh 1991).

To summarise: first, the late Hellenistic '*naos*' at Jarash represents the period during which painted plaster gradually began to occupy more space on the walls. Second, although the full range of Roman funerary painting is impossible to explore in detail here, human and animal figures are numerous, sometimes with funerary inscriptions indicating the names, ages, dates and beliefs of the deceased. This

is evidence for a transfer of identities between *polis* and *necropolis* contexts. Third, some of the painted figures begin to appear in larger (*viz. ca.* 1 m) sizes (*e.g.* animals and a mythological sphinx in an alcove at the Som Veteran tomb) (Barbet and Vibert-Guigue 1988: pl. 122) or in a seated throne position (*e.g.* Pluto, Kore and Cerberus at Marwa tomb) (Barbet and Vibert-Guigue 1994: 262).

Transition and Renewal in Byzantine Times and at Umayyad-Period Residences in the *Bādiya*

Most Byzantine-period discoveries relate to tombs or churches⁹. An interesting ‘exception’ is the Hermitage of John, cut high into the cliff of Wādī ‘Afrā, which was first observed in 1979 (Burton 1980) (FIG. 13). The rock is directly painted with non-figurative themes, with the exception of schematic fishes and birds in a cross medallion. The most curious decoration is a partially destroyed ceiling composition: to my mind, it looks like an imitation of lattice, the antique *hortus conclusus* motif, which is well-known in the occident. The yellow dots are flowers and the red ones, on white, probably roses.

In Byzantine funerary contexts, two examples are important for our survey. A Roman tomb was re-used as a chapel in a necropolis near Salt (Vibert-Guigue 1998). On one wall, a painting might represent a holy horseman (FIG. 14). In ‘Ammān, at Jebel Joffeh, a tomb excavated by the DoA displays two biblical references on either side of an alcove surrounded by a vine scroll (FIG. 15): the miracle of Lazarus on the left and the blind man being restored to sight on the right. These scenes were inscribed in Greek, helping interpretation (Zayadine 1985). The churches were in many cases painted (Michel 2001). Fallen voussoirs found in the church of the priest Wa’hil at Umm ar-Raṣāṣ (586 AD) show an apse with a holy personage seated near a frieze of birds, holding a book (Piccirillo 1993).

This painted apse introduces one of the most fascinating painted monuments in Jordan, the Umayyad bathhouse of Quṣayr ‘Amra (FIG. 16) (Bisheh and Vibert-Guigue 2007), a key monument in mural art history. First, it is located in the steppe, *viz.* the *bādiya* east of Amman. Second, 350 m² of paintings are preserved, featuring figurative compositions inspired by Greco-Roman and Byzantine iconography

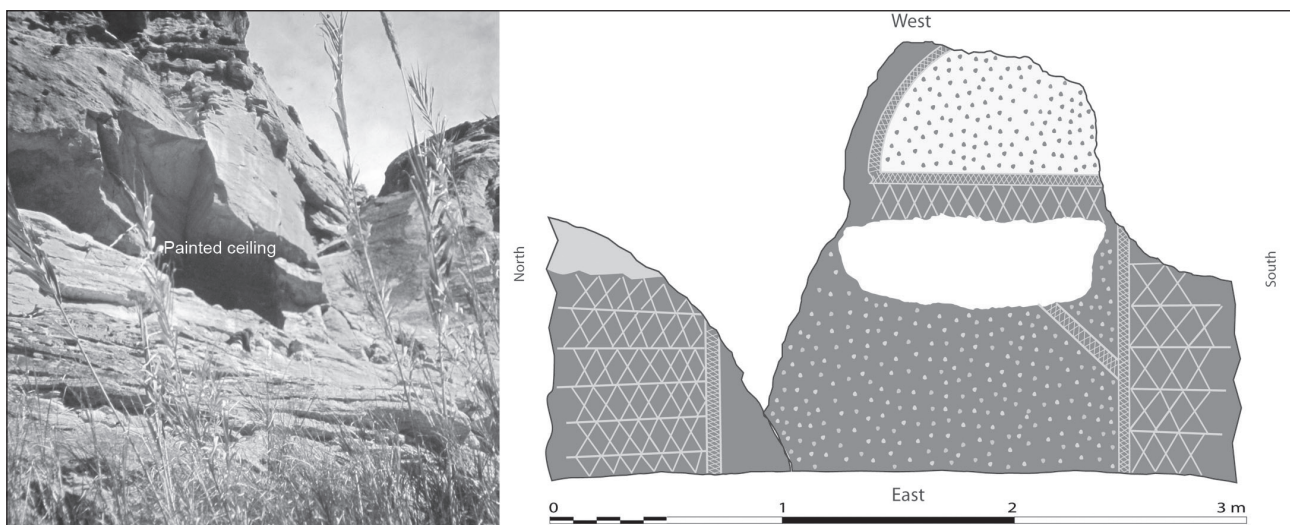

13. Ḥammām ‘Afrā - Byzantine hermitage: Rock painting - *in situ* ceiling detail (Vibert-Guigue).

9. There is insufficient space to discuss Qaṣr al-Ḥallābāt, with its architectural evolution that includes paintings and mosaics from different periods. Arce has published these new discoveries,

showing that one part of the paintings and stuccos belongs to a Ghassanid phase (Arce 2009).



14. Salṭ - Roman tomb: *in situ* Byzantine painting (Vibert-Guigue).

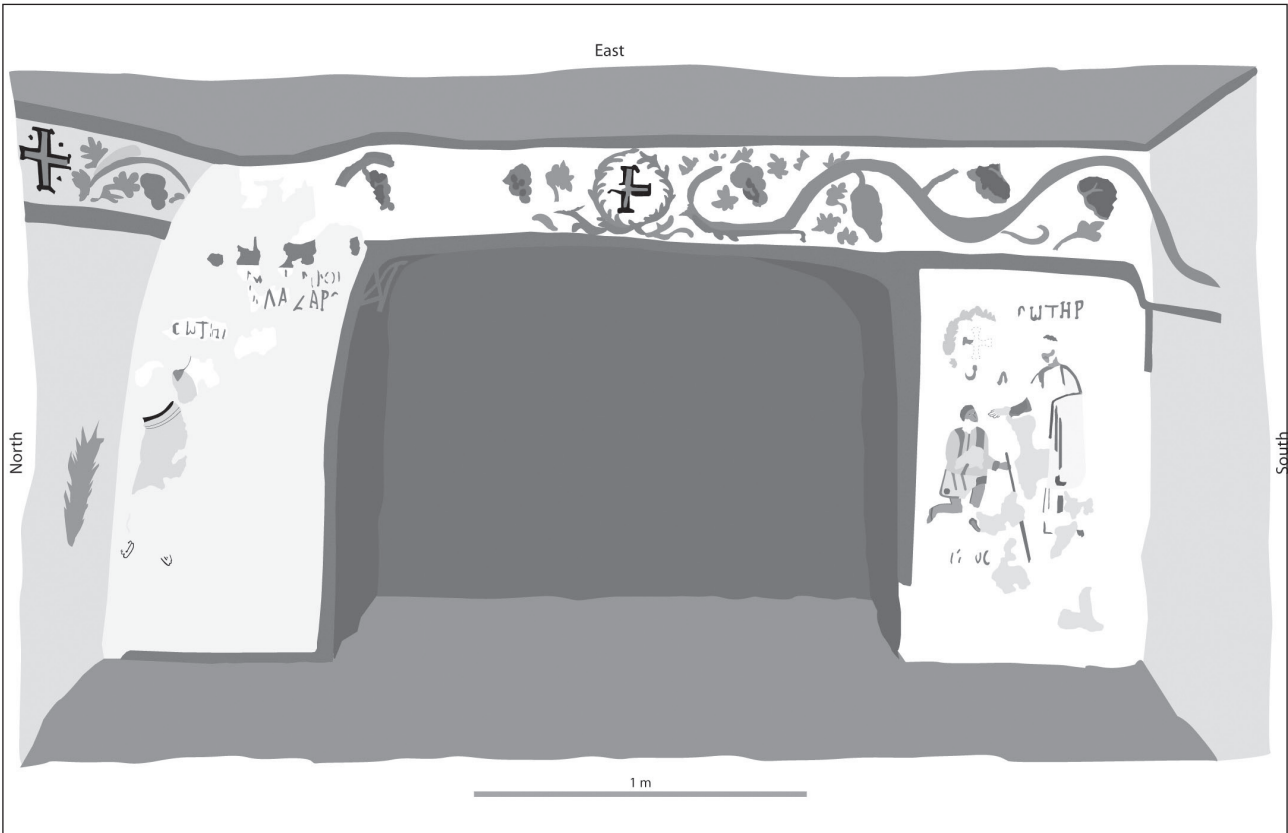

15. 'Ammān, Jabal aj-Jawfah - Byzantine tomb: *in situ* painting (Vibert-Guigue).

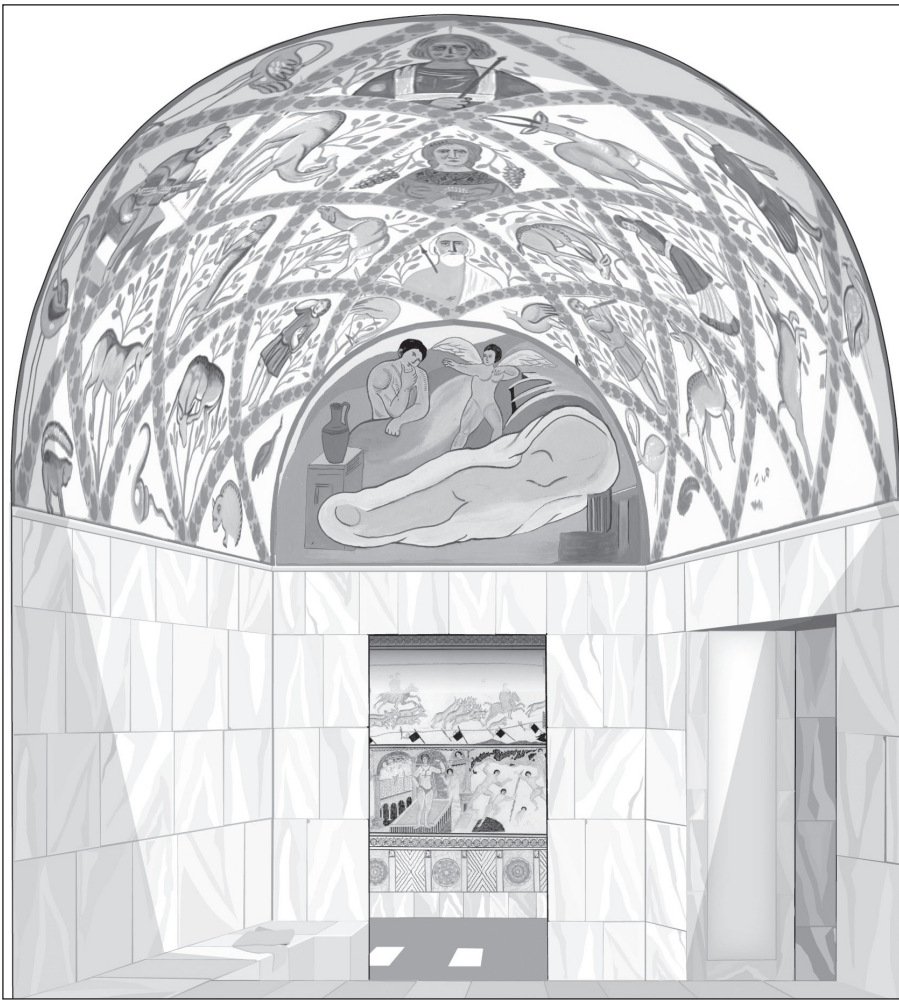

16. Qaşayr 'Amra, - Umayyad bathhouse: *in situ* painting (Vibert-Guigue).

in an Umayyad context. Third, in the context of historical Bilād ash-Shām, it is the best preserved of a series of bathhouses, all rich in decoration and some giving preference to stucco (Qaşr al-Hīr al-Gharbī; Khirbat al-Mafjar). The princely owner of Qaşayr 'Amra developed a vast iconographic program on the walls, vaults, arches and cupola, labelled in some cases in Arabic or Greek, or indeed both. Bathers would have been able to relax whilst admiring scenes of hunting, fishing, dancing and bathing. The Qaşayr 'Amra paintings represent a high point of centuries of artistic development. These diverse scenes are a kind of 'sounding board' of classical art, all combined in honour of a prince who is represented in many prestigious situations. What is interesting is that during

the Umayyad caliphate, paintings with figures existed only in residences far from the cities (Damascus, Amman, Jerusalem *etc.*).

General Aspects

The few examples listed here indicate choices between painting or stucco (or combinations thereof) that varied over time. Stucco imitating architecture is very apparent during the Hellenistic period but slowly disappears thereafter, with the exceptions of Nabataean or Roman-period temples¹⁰. Although the 'masonry style' never came back into fashion, a stucco revival under the Umayyad caliphate is clear (Qaşr al-Ḥallābāt; Ḥammām as-Sarāḥ; al-Mafraq). Through the use of painted imitations of columns (or pilasters), architectural features fol-

10. From approximately the end of the 1st century BC and the 1st century AD: Wādī Ramm (Savignac and Horsefield 1935),

Qaşr al-Bint (Zayadine 2003) and Khirbat adh-Darīḥ (Chambon 2002).

lowed another road: Roman rock-cut tombs used this technique to simulate luxurious construction, while at Quşayr ‘Amra columns are evidence of an aristocratic palatial / bathhouse way of life. Quşayr ‘Amra also represents a quantum leap, as around 500 figures and animals are represented in a single place.

By the end of the 1st century BC, teams of painters probably included at least one individual able to represent figurative scenes, and this number increased during the Umayyad period. In this last case, it is fascinating to observe the changes in scale. For example, we can compare the Nabataean miniature Eros at Baydā’ with a very similar one, but taller, at Quşayr ‘Amra (FIG. 17 [left]). This difference of scale can also be seen in the grape motif at Quşayr ‘Amra, where it starts to be larger than life-size (FIG. 17 [right]).

There are other parallels from the classical to Umayyad periods. Clio, the muse of history, in a Roman house at Humeima (Oleson 1999) can be compared with a historical allegory preserved at Quşayr ‘Amra (FIG. 18 [left]). Similarly, a young woman writing on a codex at an Abila tomb can be compared with a recently discovered scribe at Qusayr ‘Amra (FIG. 18 [right]). The *tabula ansata* motif, inscribed in Greek or Arabic, clearly shows cultural transfer through renewal, from paganism to Islam by way of Christianity (FIG. 19). The main point to focus on at Quşayr ‘Amra is a final

iconographic tendency towards megalography. For example, a man more than 2 m high was discovered in 2013 by the Italian conservation team in the west aisle of the audience hall (FIG. 20).

The vegetation theme is also interesting to study through different contexts and periods. Depictions of water, shadow and abundance, combined with fishing, hunting or animal parks (the latter derived from Persian influence), demonstrate that these were as important for the dead as for the living. The luxuriant Nabataean pergola in the Baydā’ *biclinium* cave is evidence of a mythological revival of nature associated with water coming from the cliff and the gorge (*cf.* FIG. 7). Roman tomb walls or vaults covered with roses represent funerary gardens for ritual banquets. The Christian *hortus conclusus* at Ḥammām ‘Afra represents a celestial garden on the ceiling of the hermitage near the hot springs (*cf.* FIG. 13). The importance of vegetation during the Umayyad period in the Quşayr ‘Amra paintings represents the concept of a paradise in the steppe (*bādiya*), echoed by the natural presence of wild pistachio trees in nearby Wādī al-Buṭum (*cf.* FIG. 20).

Conclusion

On the one hand, the archaeological remains of painting or stucco decoration follow trends known from the occident. This process begins in the classical period with

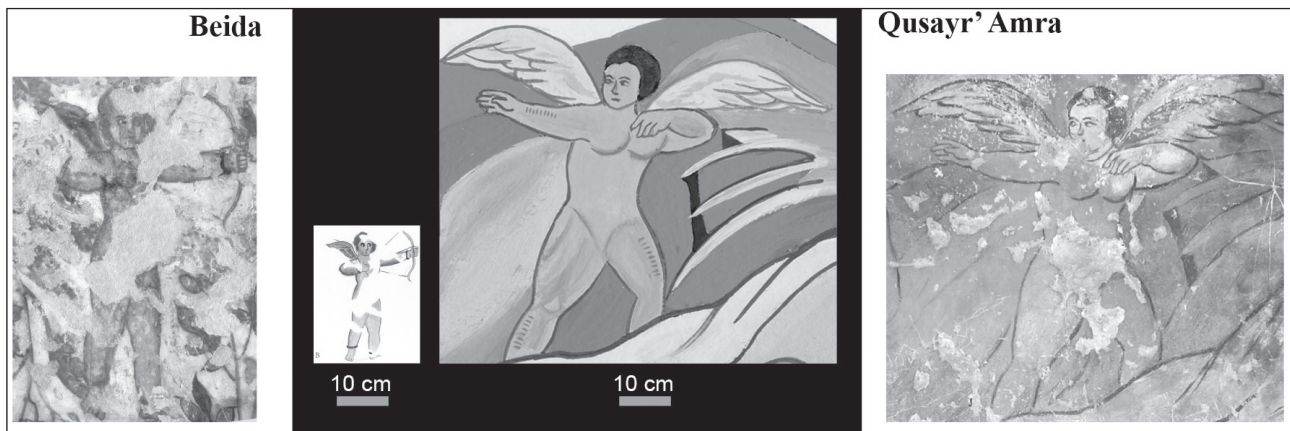

17. Parallels between Nabataean and Umayyad Eros paintings: Iconographic similarities (extremities) and size differences (centre) (Vibert-Guigue).



18. Iconographic parallels with thematic similarities: (left) the allegories *Clio* (Ḥumayma [Oleson 1999]) and *Historia* (Qusayr 'Amra [Vibert-Guigue 2007]); (right) scribes in a Roman tomb at Abila (Vibert-Guigue) and in an Umayyad painting (Qusayr 'Amra, after recent DoA - WMF - ISCR restoration [Vibert-Guigue]).



19. Iconographic parallels: Thematic similarities between Greek and Arabic inscribed *tabula ansata* from Abila tomb (above [Vibert-Guigue]), Umm ar-Rašāš church (middle [Picirillo 1994, pl. 26.5]) and Qusayr 'Amra (below, after recent DoA - WMF - ISCR restoration [Vibert-Guigue]).

imitations of architecture in stucco relief. Later, instead of stucco, painting is used to represent architectural views that go on to

include figures of increasing size. On the other hand, geological and geographical contexts and the nature of the monuments during the

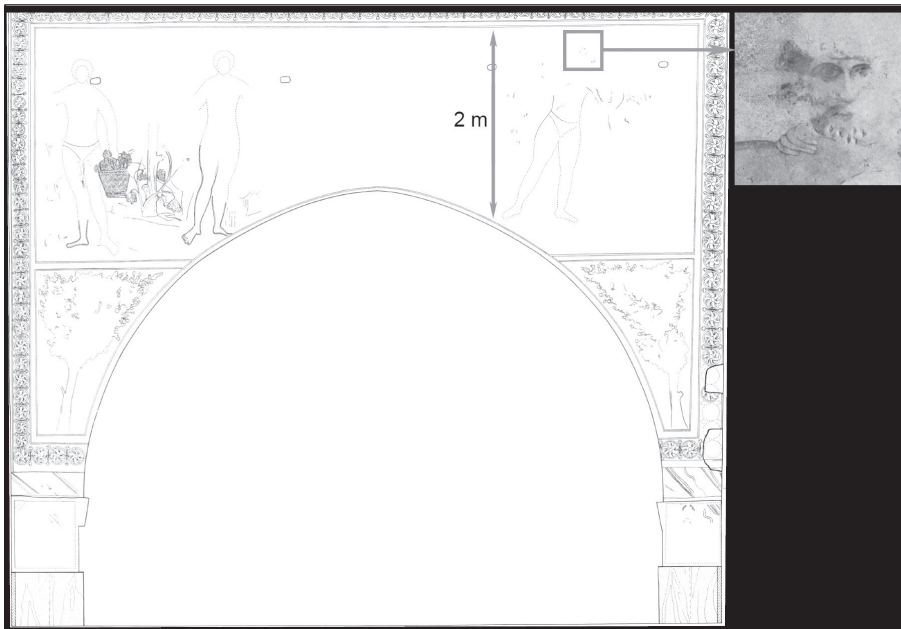

20. Megalography at Qaşayr 'Amra: west aisle, east wall (drawing Vibert-Guigue 2007; detail Palumbo, after 2012 DoA - WMF - ISCR cleaning).

Hellenistic and Nabataean periods indicate conceptual differences. It is difficult to imagine how the Qaş al-'Abd palace at 'Irāq al-Amīr was supposed to have been coated, considering the importance of the architectural orders and its larger-than-life monumental sculptures. The problem is similar at Petra, with its external rock-cut facades. It is also worth mentioning the lack of perspective in Nabataean architectural imitations, which preferred frontal views of facades in stucco or painting (Qaş al-Bint; upper corridor of the Petra Great Temple; rock-cut house in Wādī Şiyagh; villa in Wādī Mūsā). Gypsum stucco composition on flat ceilings (as at the Petra Great Temple) is also unusual in the occident. In this context, we also have to consider the absence of the two last Roman 'Pompeian styles', without generally being able to find parallels with Roman characteristics over time. This is why the answer to the question "Will this interpretative overview withstand more exhaustive investigation?" is probably "No". Such a long and complex cultural period needs more archaeological examples to be sure of all the cultural nuances.

What is very interesting from the Qaşayr 'Amra bathhouse imagery is that Umayyad painted art is completely figurative in the *bādiya*, far from the cities. Is this phenomenon similar to that observed at the Nabataean *biclinium* at Bayḍā'? Do we also have to consider that large-scale human representation was first employed in Nabataean temples or 'natural sanctuaries', as the archaeological evidence seems to say?

The main problem is that more evidence is required. We therefore encourage archaeologists to publish their discoveries, from the smallest to the most important, including fragments as well as preserved surfaces on walls or rock. Together they will fill the gaps in our knowledge of painting and stucco, as will the graffiti and painted inscriptions that sometimes shed light on discoveries¹¹.

This colloquium title of 'Transparent Borders' helps us to bear the idea of teams of painters or stucco artists in mind. From different origins, and working in different geographical contexts (valley, mountain, *bādiya* etc.), they had to be aware of different knowledge, find *in situ* natural resources (sand, lime, pigments etc.)

11. Inscriptions or 'graffiti' are frequent and must be carefully studied. They can be painted, scratched or drawn with charcoal (Darby-1996), or be on plaster. Through their language (Nabataean, Greek, Kufic or bilingual as at Qaşayr 'Amra) and mean-

ing, they give local information, whether contemporaneous or not. Milestones or columns also preserve painted inscriptions (Graf 1995). Imbert has published much research on Arabic examples (Vibert-Guigue and Bisheh 2007).

and adapt themselves to different styles. In view of the wide variety of regional sites, cultural capitals (Alexandria, Antioch *etc.*), roads and maritime routes through the Greek and Roman islands, binary analyses are difficult to sustain. In pictures, Qaşayr ‘Amra reminds us of the importance of these artists, who decorated a complete vault in the audience hall with thirty-two panels representing builders and, maybe, some of those responsible for preparing the mortar and painting it.

Bibliography

- ‘Amr, K. and al-Momani A. 2001. Preliminary Report on the Archaeological Component of the Wādî Mûsâ Water Supply and Wastewater Project (1998-2000). *ADAJ* 45: 253-285.
- Arce, I. 2009. *Coenobium*, Palatium and Hira: The Ghassanid Complex at al-Hallâbât. Pp. 937-966 in *Studies in the History and Archaeology of Jordan X*. Amman: Department of Antiquities.
- Akrawi, A. and L. Shekede. 2010. A Unique Nabataean Wall Painting. Pp. 214-219 in *Petra: Conservation In Situ, Conservation and the Eastern Mediterranean: Contributions to the 2010 IIC Congress*, Istanbul.
- al-Muheisen, Z. and Villeneuve, F. 1993. Khirbat adh-Dharih, *Liber Annuus* 43: 486-489.
- Aslan, Z., and Shaer M. 1996. Methodology for the Conservation of the Facade in Petra. *ADAJ* 40: 467-72.
- Barbet, A., Vibert-Guigue, C. 1988. Les peintures des nécropoles romaines d’Abila et du Nord de la Jordanie, *BAH CXXX*.
- 1994. Les peintures des nécropoles romaines d’Abila et du Nord de la Jordanie, *BAH CXXX*.
- Barbet, A. 1995. Les caractéristiques de la peinture murale à Pétra. Pp. 383-389 in *Studies in the History and Archaeology of Jordan V*. Amman: Department of Antiquities.
- Bisheh, G. 2000. Two Umayyad Mosaic Floors from Qastal. *Liber Annuus*, L, 2000: 431-437.
- Chambon, A. 2002. Le décor stucé de l’intérieur du temple in *Khirbat adh-Dharih, Des Nabatéens au premier Islam*, Amman, capitale culturelle du monde arabe 2002, Amman.
- Darby R. and Darby E. 2016. The Writing on the Wall: Recent Discoveries from the Late Fort at ‘Ayn Gharandal. Pp. 223-231 in *Studies in the History and Archaeology of Jordan 12*. Amman: Department of Antiquities.
- Daviau, P.M.M. *et alii*. 2010. *Excavations at Tall Jawa, Jordan, 4, The Early Islamic House*. Leiden. Boston.
- Egan, E.C. 2002. Stucco Decoration from the south Corridor of the Petra Great Temple: Discussion and Interpretation. *ADAJ* 46: 347-361.
- Eristov, H., Seigne, J. *et alii*. 2002. Jordanie: le naos de Théon à Jérash. *Archeologia* 385 : 26-38.
- Eristov, H., Seigne J., (et coll.). 2003. Le « naos » hellénistique du sanctuaire de Zeus olympien à Jerash (Jordanie) *Topoi* suppl. 4: 269-298.
- Eristov, H. and Vibert-Guigue, C. 2013. Images et textes funéraires dans un hypogée de Gerasa: une redécouverte. Pp. 395-402 in *Changes and Challenges*, in *Studies in the History and Archaeology of Jordan 11*. Amman: Department of Antiquities.
- Graf, D.F. 1995. Milestones with Uninscribed Painted Latin Texts. Pp. 417-425 in *Studies in the History and Archaeology of Jordan V*. Amman: Department of Antiquities.
- Groot, J. 1980. Wall Decoration. Pp. 75-85: The Excavations at Araq el-Emir, (Lapp N. L., and cont.). *ASOR* 47.
- Hammond, Ph.C. 1996. *The Temple of the Winged Lions, Petra, 1974-1990*. Arizona.
- Joukowsky, M.S. 2007. *Petra Great Temple, Volume II: Archaeological Contexts of the Remains and Excavations*.
- Karasneh, W. 1991. *Excavation Report*. Department of Antiquities. Amman.
- Kerner, S. 2002. Gadara-Schwarzweiße Stadtwischen Adjlun und Golan. Pp. 125-136 in A. Hoffmann, S. Kerner (eds), *Gadara-Gerasa und die Dekapolis*. Mayence.
- Kolb, B. 2002. Excavating a Nabataean Mansion, *Near Eastern Archaeology* 65: 260-264.
- Kropp, A.J.M. 2009. Nabataean Petra: The Royal palace and the Herod connection. *Boreas, Münstersche Beiträge zur Archäologie*, 32, 43-59.
- Lapp, P. W. 1963. The Second and Third Campaigns at ‘Arâq el-Emîr. *ASOR* 171: 8-39.
- MacDonald, B. 1980. The Hermitage of John the Abbot at Hammam ‘Afra, Southern Jordan. *Liber Annuus XXX*: 351-364.
- McKenzie, J. 1990. The Architecture of Petra, *British Academy Monographs in Archaeology* 1. New-York.
- Michel, A. 2001. Les églises d’époque byzantine et umayyade de la Jordanie Ve-VIII^e siècle (provinces d’Arabie et de Palestine). Typologie architecturale et aménagements liturgiques. *Bibliothèque de l’Antiquité tardive*, 2.
- Musil, A. 1907. *Kusejr ‘Amra*, Kaiserliche Akademie der Wissenschaften, Vienna.
- Oleson, J.P. 1999. Humeima. Pp. 513-14 in P. Bikai, V. Egan (eds), “Archaeology in Jordan”. *American Journal of Archaeology* 103: 485-520.
- Piccirillo, M. 1993. La chiesa del prete Wa’il a Umm al-Rasas-Kastron Mefaa in Giordania, Pp. 313-334 in *Early Christianity in Context, Monuments and*

- documents, F. Manns and E. Alliata (eds), *Studium Biblicum Franciscanum, Collectio maior*, 38.
- Politis, K.D. 2012. *Sanctuary of Lot at Deir 'Ain 'Abata in Jordan. Excavations 1988-2003*. Jordan Distribution Agency.
- Savignac, M.-R. and Horsefield, G. 1935. Le temple de Ramm. *RB* 44: 245-278.
- Shaer, M. 2003. *The Decorative Architectural Surfaces of Petra*, Thesis, Technique University, Munich.
- Smith, R. 1981. Preliminary Report on a Second Season of Excavation at Pella, Jordan. Spring 1980. *ADAJ* 25: 311-326.
- Tell, S. 1995. Frescoes: From the Decapolis to the Umayyad Palaces. Pp. 375-382 in *Studies in the History and Archaeology of Jordan V*. Amman: Department of Antiquities.
- Tuttle, Ch. A. 2013. *The Temple of the Winged Lions Cultural Resource Management Initiative (TWLCRM): A Holistic Model for Preserving, Presenting, and Protecting the World Heritage Site of Petra*. A paper presented in the International Conference on the History and Archaeology of Jordan. Berlin, Germany.
- Twaissi, S., Abudanh F. and Twaissi Q. 2010. The Identity of the Nabataean 'Painted House' Complex at Baidha, North-West Petra. *PEQ* 31-42.
- Vibert-Guigue, C. 1998. La peinture d'un tombeau à as-Salt. *ADAJ* XLII: 369-374.
- 2010. Une peinture dans la roche du Wadi Siyagh à Pétra. Pp. 917-923 in *Atti del X Congresso Internazionale dell'AIPMA*, Bragantini (ed.), Napoli, 17-21 settembre 2007, *AION ArchStAnt Quad.* 18.
- Vibert-Guigue C. and Bisheh Gh. 2007. Quşayr 'Amra. Les peintures d'un bain omeyyade, *Bibliothèque archéologique et historique* 179 / *Jordanian Archaeology* 1.
- Vörös, G. 2013. *Machaerus I. History, Archaeology and Architecture of the Fortified Herodian Royal Palace and City overlooking the Dead Sea in Transjordan*. Final Report of the Excavations and Surveys 1807-2012, Milan.
- Will, E. and Larché, F. (et alii). 1991. 'Iraq al-Amir, Le château du tobiade Hyrcan. *Bibliothèque archéologique et historique* 132.
- Larché, F., 'Iraq al-Amir. 2005. Le château du tobiade Hyrcan, volume II (texte et illustration): Restitution et Reconstitution, *Bibliothèque archéologique et historique* 172.
- Zayadine, F. 1985. Jebel el Jôfeh: une tombe Byzantine. *Syria* LXII: 153.
- 1986. Peintures murales et mosaïques à sujets mythologiques en Jordanie. *Bulletin de correspondance hellénique*, XIV: 407-432.
- 1987. Decorative Stucco at Petra and other Hellenistic Sites. Pp. 131-142. *Studies in the History and Archaeology of Jordan* III. Amman: Department of Antiquities.
- Zayadine, F., Larché F., Dentzer-Feidy J. 2003. *Le Qasr el-Bint de Pétra. L'architecture, le décor, la chronologie et les dieux*, Paris.

